

All rights reserved. Reproduction  
 without permission is prohibited.  
 Alle rechten voorbehouden. Reproductie  
 zonder toestemming is strafbaar.  
 authority from the proprietor.

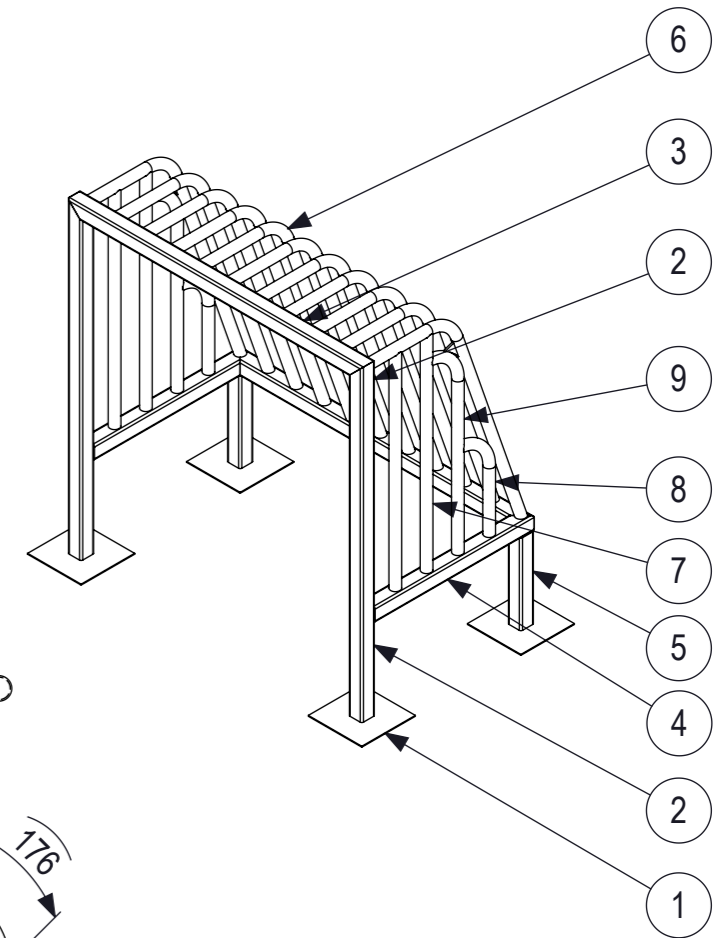

0 10 20 30 40 50 60 70 80  
 mm

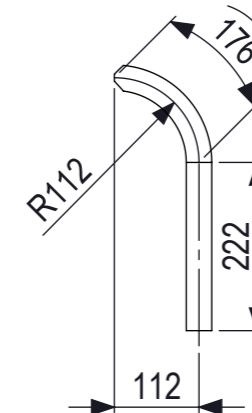
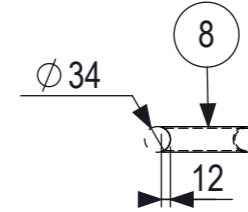
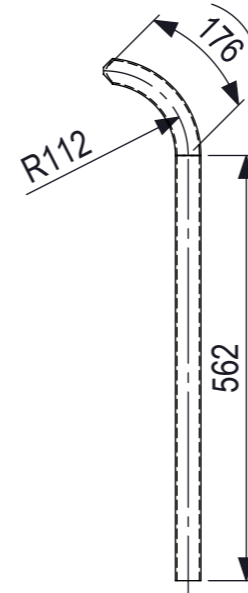
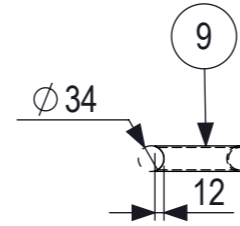
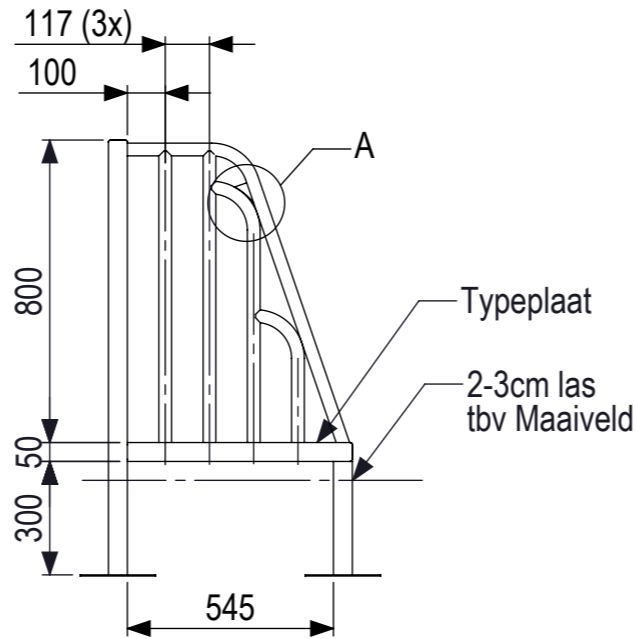
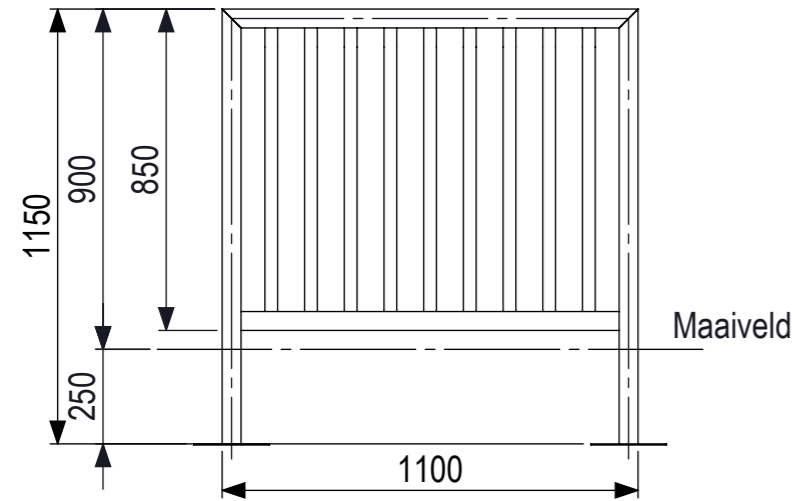
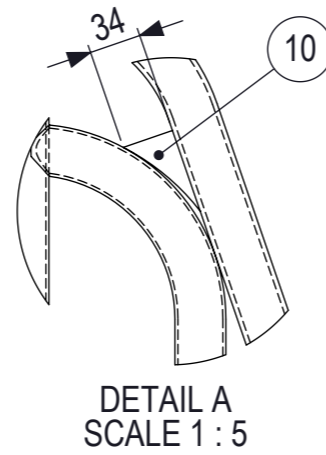
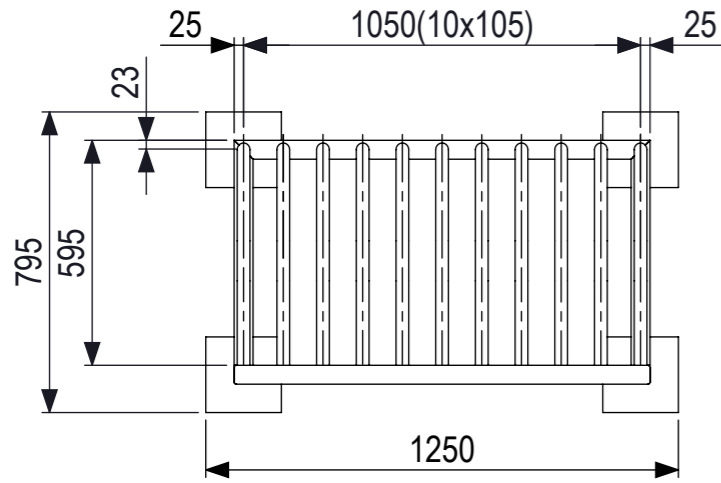
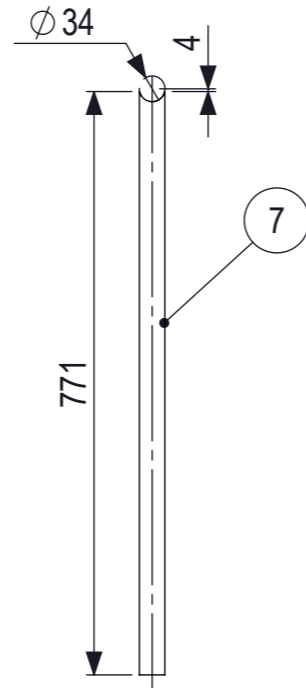
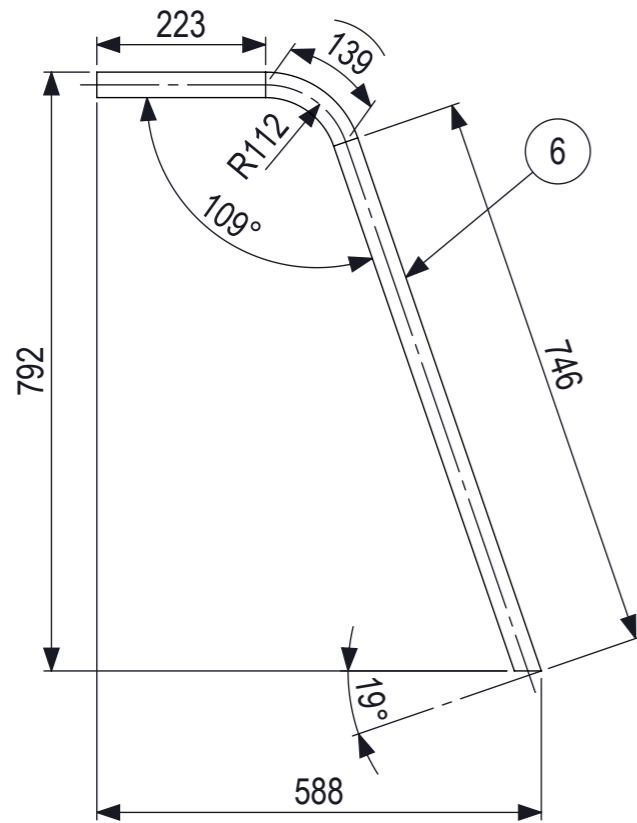

Posnr.	Aantal	Beschrijving	Artikelnr.
10	2	Schotje vingerbeklemming spijlendoel 6mm	104149A
9	2	Buis rond 33,7x2 RVS 304 ongegloeid	100000-988^1207C
8	2	Buis rond 33,7x2 RVS 304 ongegloeid	100000-648^1207C
7	4	Buis rond 33,7x2 RVS 304 ongegloeid	100000-771^1207C
6	11	Buis rond 33,7x2 RVS 304 ongegloeid	100000-1135^1207C
5	2	Buis vierkant 50x50x3 RVS 304 ongegloeid	100543-300^1207C
4	2	Buis vierkant 50x50x3 RVS 304 ongegloeid	100543-595-1x45°^1207C
3	2	Buis vierkant 50x50x3 RVS 304 ongegloeid	100543-1100-2x45°^1207C
2	2	Buis vierkant 50x50x3 RVS 304 ongegloeid	100543-1150-1x45°^1207C
1	4	Plaat 2500x1250x3 RVS 304 wgw finish 1D	100309-200x200^1207C

<p><b>Ijlander BV</b>          Oude Dijk 10          8096 RK Oldebroek   The Netherlands          T +31 (0)525 633420   F +31 (0)525 631067          info@ijlander.com   www.ijlander.com</p>	oppervlakte ruwheid surface roughness DIN ISO 1302 <input checked="" type="checkbox"/> <input checked="" type="checkbox"/> <input checked="" type="checkbox"/>	alg. ruwheid gen. roughness 3.2	eenheid/unit mm	datum date 12-3-2018	naam name TB	
	vorm- en plaattoleranties geometrical tolerancing DIN ISO 1101 <input type="checkbox"/> <input type="checkbox"/> <input type="checkbox"/> <input type="checkbox"/> <input type="checkbox"/> <input type="checkbox"/>	toelaatbare afwijkingen voor lineaire maten (m.u.v. gebroken kanten) admissible deviations for linear dimensions (excepting broken edges)				
alg. toleranties gen. tolerancing DIN 7168-m	lineaire maat linear dimension	afwijking/deviation	<input type="checkbox"/> 0,5 <input type="checkbox"/> 6 <input type="checkbox"/> 30 <input type="checkbox"/> 120 <input type="checkbox"/> 400 <input type="checkbox"/> 1000 <input type="checkbox"/> 2000 <input type="checkbox"/> 4000 <input type="checkbox"/> 8000	<input type="checkbox"/> ±0.1 <input type="checkbox"/> ±0.2 <input type="checkbox"/> ±0.3 <input type="checkbox"/> ±0.5 <input type="checkbox"/> ±0.8 <input type="checkbox"/> ±1.2 <input type="checkbox"/> ±2 <input type="checkbox"/> ±3	vervangt/replaces	
proj. 	benaming/name <b>Minidoel 1.1x0.9 m</b>	tekeningnummer/drawingnumber <b>1207C</b>	blad/sheet 1 - 1	wijz./rev. -	form./size A3	

△ C