

REVISIONS				
ZONE	REV.	DESCRIPTION	DATE	APPROVED
F1	A	Building Block C mini toegevoegd op INS-tekening	25-4-2019	

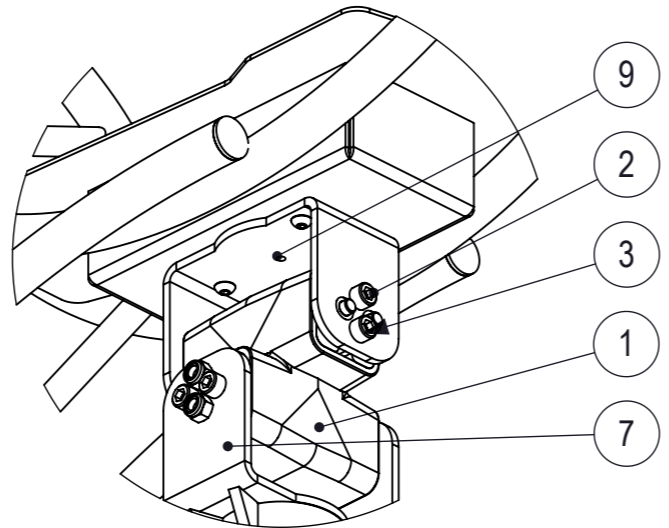

DETAIL A
SCALE 1 : 5

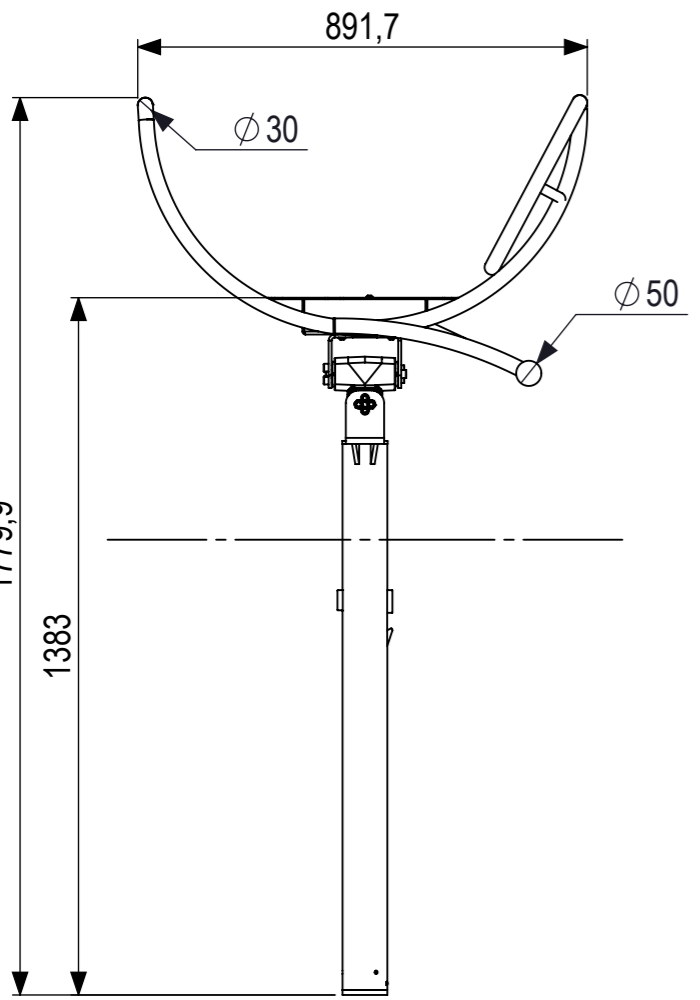
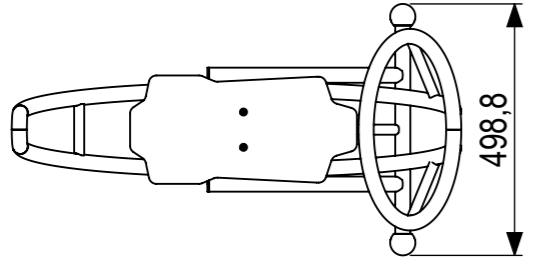
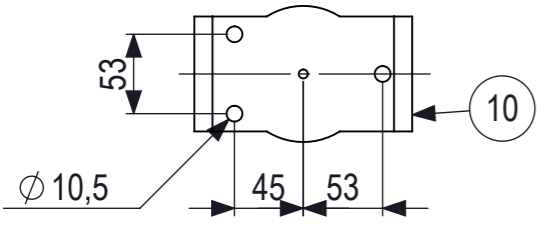
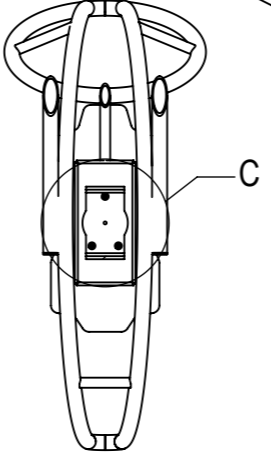

SECTION B-B

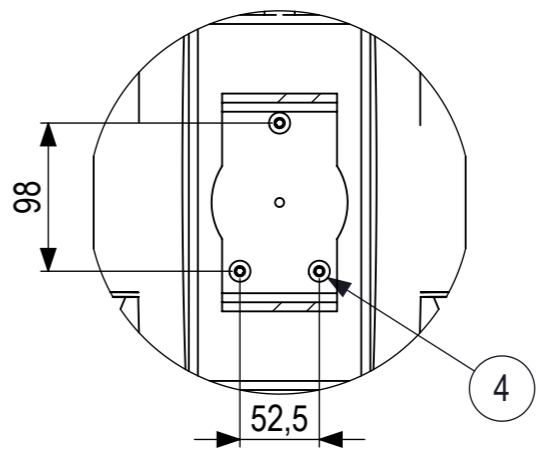
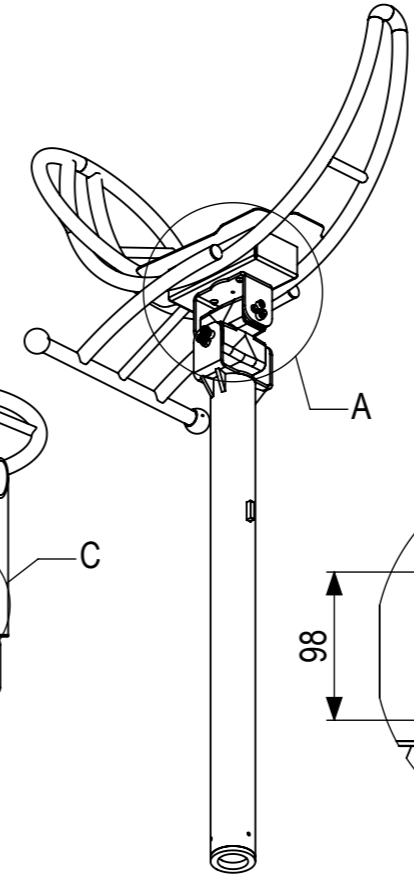
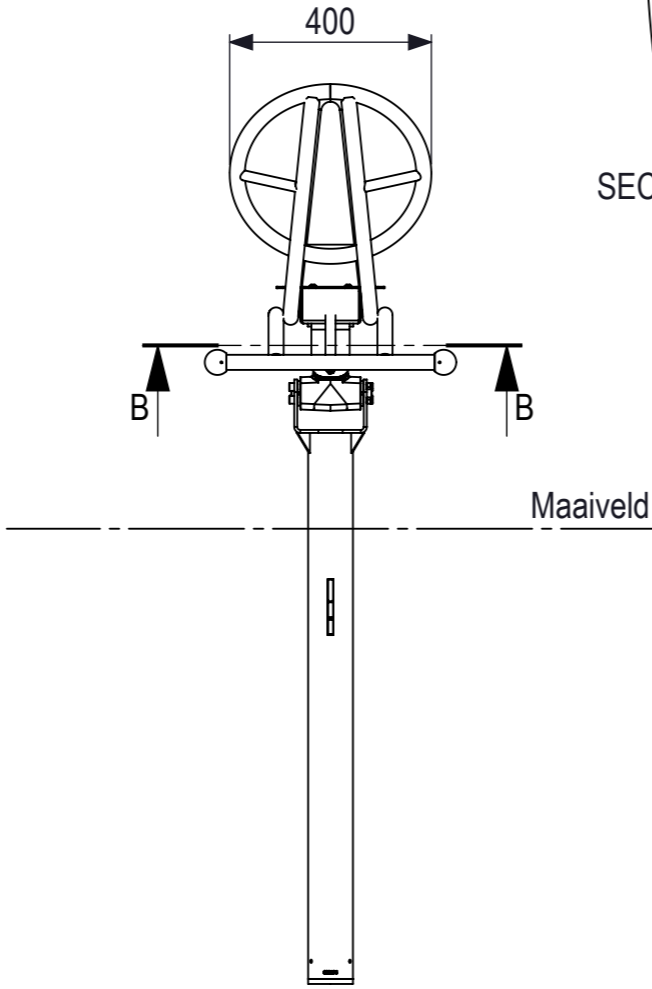

DETAIL C
SCALE 1 : 5

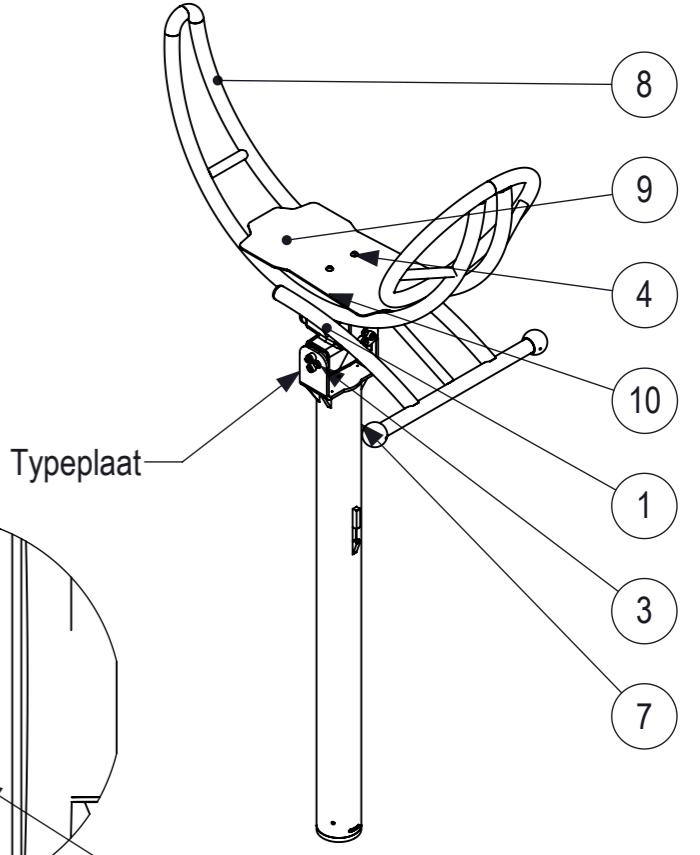



Posnr.	Aantal	Beschrijving	Artikelnr.
10	1	Zetwerk 335x90x6 rosta-AK 38 houder	101569A
9	1	zitting hobbel snijden ond-1000-0142	101025
8	1	Lassamenstelling Bovenkant Hobbelmotor	943993
7	1	Lassamenstelling CP-staander Rosta h=1144	943991-CP
6	3	Moer M8 din 933 RVS A2	100839
5	3	Sluitring din125 M8 rvs A2	100360
4	5	Torx met pin M8x16BH ISO 7380 RVS A2	100320
3	8	Borgmoer M10 din 985 rvs A2	100343
2	8	M10x150 met binnenzeskant DIN 912 RVS A2	101679
1	1	Rosta rubberverend element-AK 38 verzink	101555

Ijlander BV
 Oude Dijk 10
 8096 RK Oldebroek | The Netherlands
 T +31 (0)525 633420 | F +31 (0)525 631067
 info@ijlander.com | www.ijlander.com

IJSLANDER
 proj.  benaming/name
 schaal/scale
1:15

Click & Play - Hobbelmotor
 CP-1220A

oppervlakte ruwheid surface roughness DIN ISO 1302 	alg. ruwheid gen. roughness 3,2 	eenheid/unit mm	datum date 25-4-2019	naam name AW
vorm- en plaatstoleranties geometrical tolerancing DIN ISO 1101 	alg. toleranties gen. tolerancing DIN 7168-m	toelaatbare afwijkingen voor lineaire maten (m.u.v. gebroken kanten) admissible deviations for linear dimensions (excepting broken edges)	getekend drawn status klant akk.	norm EN-1176
lineaire maat linear dimension afwijking/deviation	> 0,5 ≤ 6 ±0.1	6 30 ±0.2	30 120 ±0.3	120 400 ±0.5
			400 1000 ±0.8	1000 2000 ±1.2
			2000 4000 ±2	4000 8000 ±3
vervangt/replaces		tekeningnummer/drawingnumber CP-1220A	blad/sheet 1 - 1	wijz./rev. -
			form./size A3	